

Location: _____



MC-12D-HS

DOUBLE VERTICAL ADJUSTABLE HUB AND SPIGOT WATER CLOSET CARRIER (FOR SIPHON JET AND BLOWOUT TOILETS)

Specification: MIFAB® Series MC-12D-HS double, vertical, adjustable hub and spigot water closet carrier with lacquered cast iron fitting, 2" (51) no hub vent connection, lacquered cast iron gasketed adjustable faceplates, universal floor mounted cast iron foot supports, adjustable 8" tapered thread ABS nipples with integral test caps, neoprene bowl gaskets, hardware, threaded rod protectors and polished chrome plated finishing cap nuts.

Function: Used when through the slab pipe connection is required with back to back water closets installed on a common stack. Adjustable faceplate design permits installer to set water closets to the desired height from the finished floor, relative to the position of the vertical carrier fitting within the stack system. Typical for off the floor plumbing fixtures that are wall mounted and have no contact with the finished floor. The closet carrier is completely concealed within the wall and supports the load of the fixtures through a faceplate and foot support system that is anchored to the floor. Sanitation underneath the fixtures is more efficiently and economically maintained when installed off of the floor compared to floor mounted.

Note: 14 1/2" (368) minimum space required between front of foot supports. 9" (229) minimum in wall space required between back of in wall foot supports.

Note: Foot supports and faceplate are assembled at the factory before shipment in the typical siphon jet water closet configuration and are reversible for the blowout water closet design.

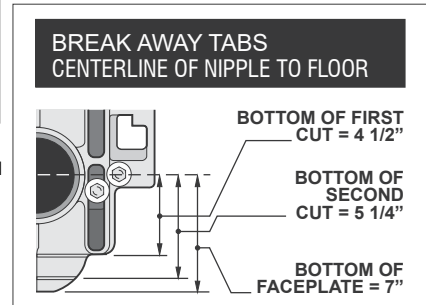
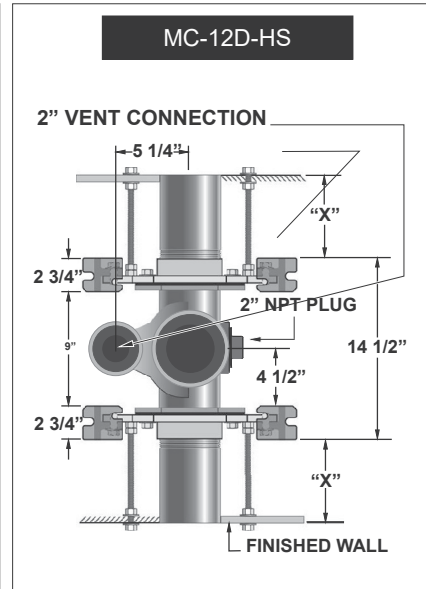
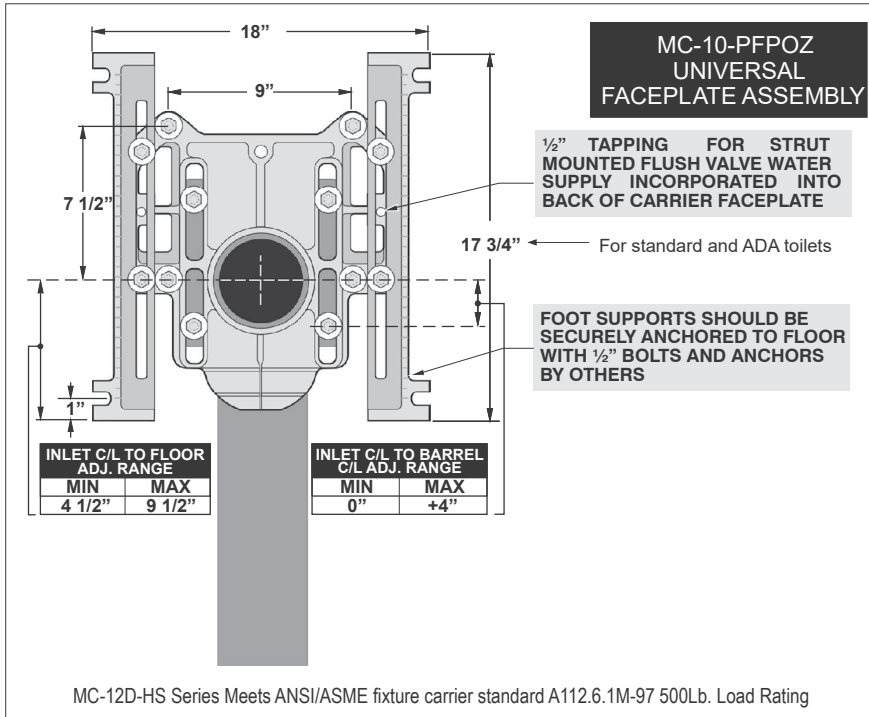

MODEL NO.	DESCRIPTION
MC-12D-HS	Double - back to back

Note: 8" tapered thread ABS nipple shipped standard with MC-10 Series carriers. The universal faceplate assembly accepts all nipple variations, rolling thread (-OR), cast iron (-CI) and tapered thread ABS with adjustable horn (-AH).

***NOTE:** MC-14 fixed vertical or MC-15 vertical offset recommended for most applications

SUFFIX	OPTIONAL VARIATIONS
-AH8	8" ABS nipple with adjustable horn
-AH12	12" ABS nipple with adjustable horn
-BA	Buy American Act compliant product
-CI-4	4" rolling thread cast iron nipple
-CI-6	6" rolling thread cast iron nipple
-CI-8	8" rolling thread cast iron nipple
-CI-12	12" rolling thread cast iron nipple
-CI-24	24" rolling thread cast iron nipple
-FM	Floor mount, back outlet fixture support
-HD-750	750 lb. rated heavy duty
-HDX	1,000 lb. rated extra heavy duty
-OR8	8" rolling thread ABS nipple
-OR12	12" rolling thread ABS nipple

-PA	Pennsylvania Steel Act compliant product
-PFAB	Prefabricated carrier
-01	Neoprene bowl gasket (MC-10-PBG)
-1	Finishing / Tiling Frame (MC-10-1-PTFK)
-3	Rear anchor support (MC-10-3-PRSFK)
-10	Auxiliary support, recommended with nipple lengths over 12"(MC-10-AFS)
-12	12" tapered thread ABS nipple* (MC-10-PN12-31)
-13	All galvanized
-14	Vandal proof finish trim (MC-10-PFH-14)
-17	Test plug for custom cast iron nipples
-19	Nipple wrench (MC-10-PCW)
-20	Flush valve support (MC-10-FVS)
-22	Less fitting

CALIFORNIA PROPOSITION 65 WARNING. This product contains chemicals known to the State of California to cause cancer and birth defects or other reproductive harm.

Job Name: _____
 Section No: _____
 Schedule No: _____

Page No: _____
 Contractor: _____
 Purchase Order No: _____