

Location:



FS720

**12" x 12" 6" FLOOR AREA AND
INDIRECT SANITARY WASTE DRAIN**

Specification: MIFAB® Series FS720, 12" x 12" x 6" deep cast iron floor area and indirect sanitary waste drain complete with white acid resistant porcelain enamel coated interior and loose set grate. Anti-splash aluminum dome strainer included.

Function: Used in kitchens, restaurants, grocery stores, hospitals, schools, and other areas that require a large volume sanitary drain. The light duty grate is not suitable for foot traffic.

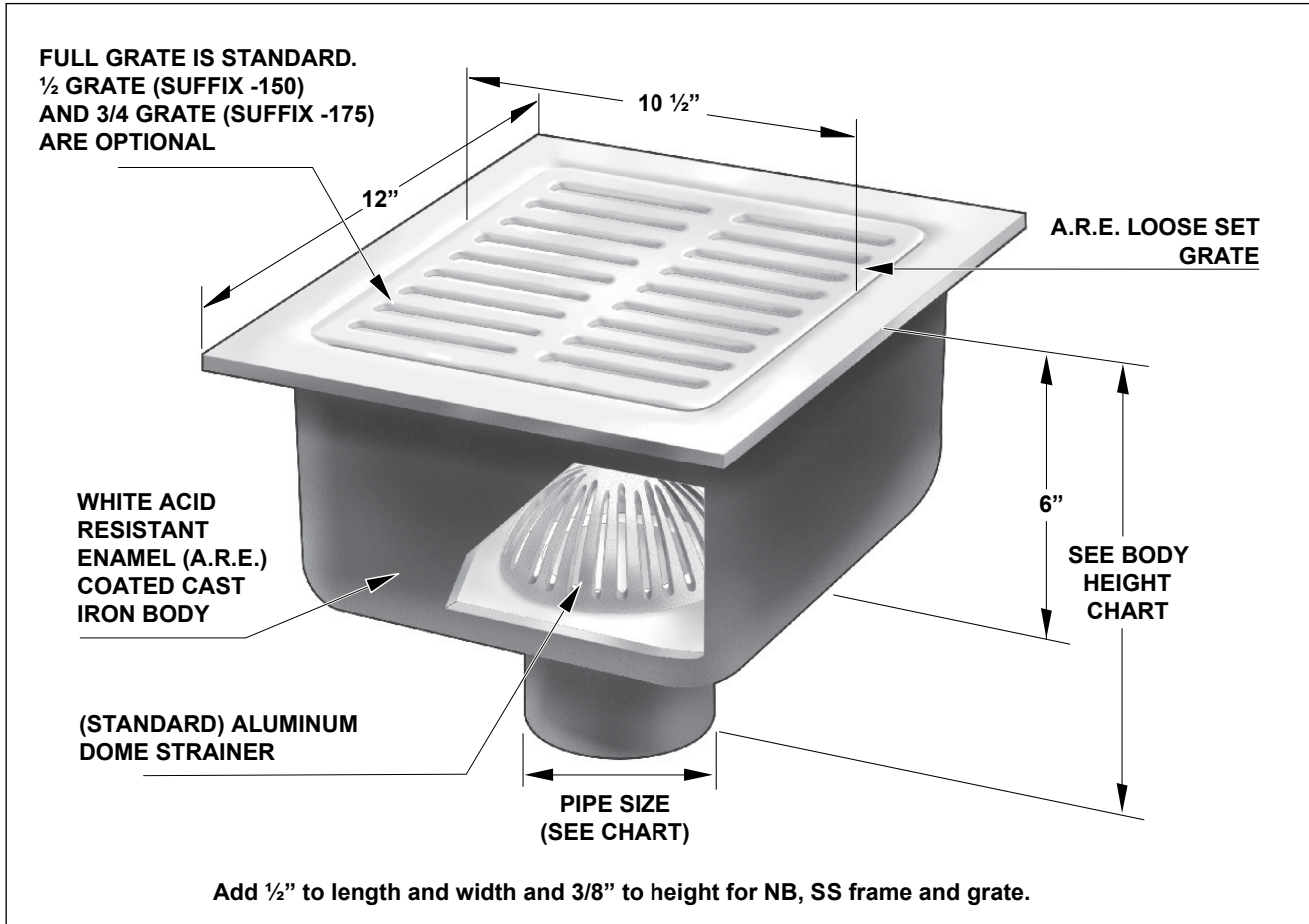

*Indicates outlet size and connection available with transition outlet body only.

**4" Inside Caulk Outlet body only available with -FL anchor flange Outlet sizes indicated by the * are available with the transition outlet body only

PIPE SIZE	BODY HEIGHT		
	NO HUB (STANDARD)	PUSH ON (P)	INSIDE CAULK (X)
2" (51)	7 3/4" (197)	*8 7/8" (225)	*10" (254)
3" (76)	7 3/4" (197)	7 3/4" (197)	8 5/8" (219)
4" (102)	7 3/4" (197)	*8 7/8" (225)	**10" (254)

SUFFIX	OPTIONAL VARIATIONS:	SUFFIX	OPTIONAL VARIATIONS:
-22	Less grate	(Standard)	No hub outlet
-150	1/2" grate	P	Push on outlet
-175	3/4" grate	X	Inside caulk outlet

Job Name: <input type="text"/>	Page No: <input type="text"/>
Section No: <input type="text"/>	Contract: <input type="text"/>
Schedule No: <input type="text"/>	Purchase Order No: <input type="text"/>