

Location:



MIFAB®

FD212TC-49

SHOWER / FLOOR DRAIN

Specification: MIFAB® Series FD212TC-49 lacquered cast iron floor drain with anchor flange, cast iron clamp ring with weepholes for waterproofing membrane, and polished chrome plated strainer.

Function: Used in showers, kitchens, restrooms and other membrane finished areas. Round, adjustable strainer is used with all types of poured finished floors. Membrane clamp is provided to secure the waterproofing membrane.

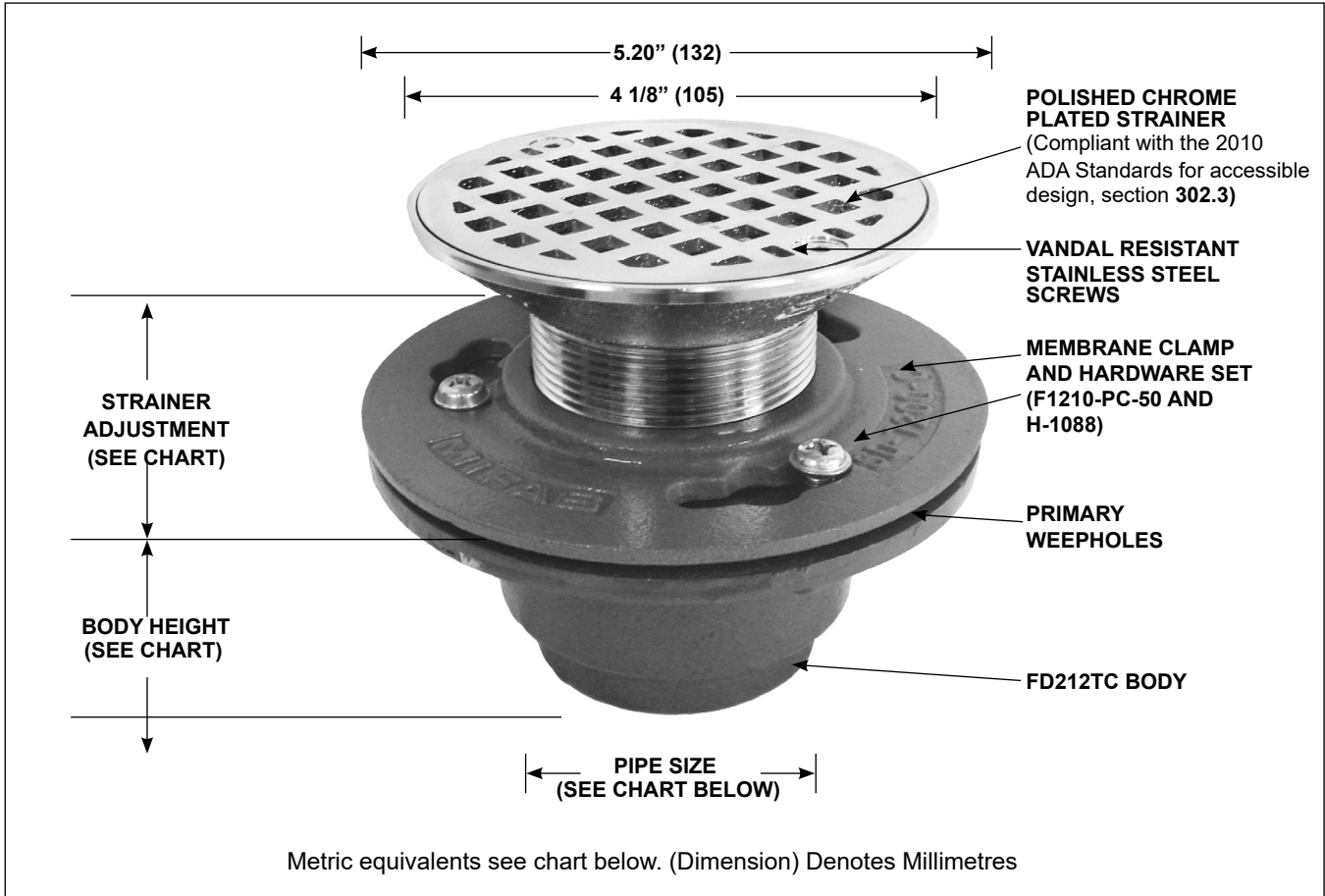

STRAINER DIAMETER	STRAINER ADJUSTMENT		ANSI/ASME RATING		PIPE SIZE	BODY HEIGHT
			FREE AREA	LOAD RATING		THREADED (T)
	MIN	MAX		C.P. (-49)		
4 1/8" (105)	1 1/4" (32)	2 3/8" (60)	5.0 in ² (3226 ²)	UP TO 2,000 LBS.	2" (52)	2 5/16" (59)

Job Name: <input type="text"/>	Page No: <input type="text"/>
Section No: <input type="text"/>	Contract: <input type="text"/>
Schedule No: <input type="text"/>	Purchase Order No: <input type="text"/>