

Location: _____



F1640-L

**12" DIAMETER
BLOOD AND WATER DRAINS**

Specification: MIFAB® Series F1640-L, 12" (305) diameter blood and water drain set consisting of two lacquered cast iron bodies with anchor flange and weepholes. One body furnished with a 12" (305) diameter lacquered cast iron adjustable top assembly and special duty ductile iron grate. The other body furnished with a solid gasketed ductile iron cover with lift ring. The top assemblies are interchangeable with either body. (For membrane floors, add Suffix -C for the membrane clamp.)

Function: Used in packing house slaughtering areas. The slotted grate drain permits drainage of blood to a separate holding tank while the gasketed covered drain adjacent is connected to the sewer. The gasketed cover is to be removed and placed into the drain holding the slotted grate during washdown, and the slotted grate is to be placed in the drain previously holding the gasketed cover. This is to ensure that water used in the cleaning operation will be directed to the sewer and not to the blood storage tank.

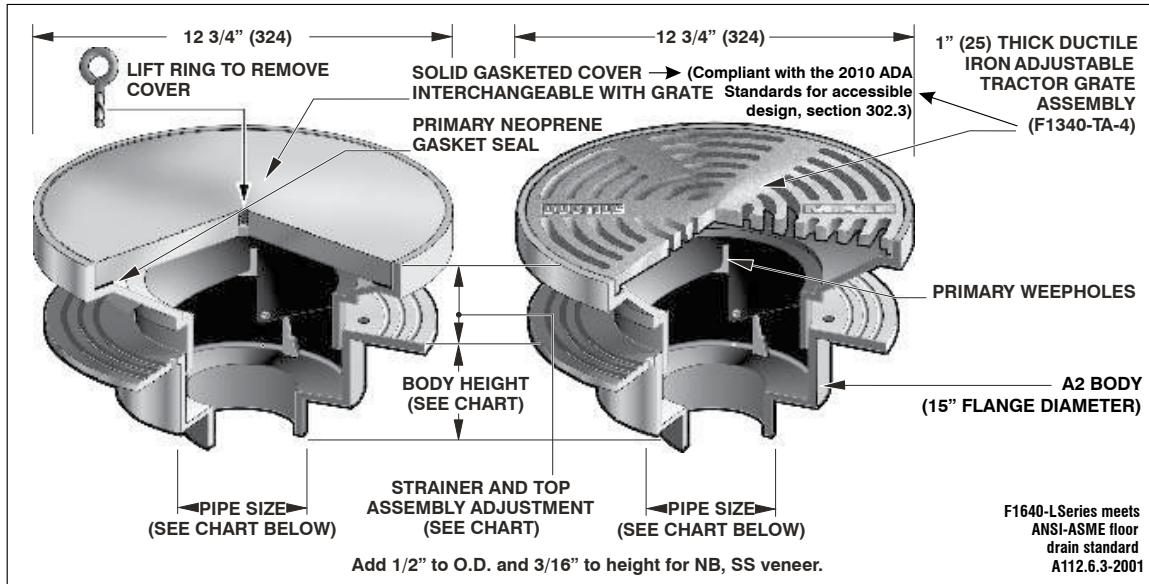

STRAINER AND TOP ASSEMBLY DIAMETER	STRAINER AND TOP ASSEMBLY ADJUSTMENT		ANSI/ASME RATING		PIPE SIZE	BODY HEIGHT				
	MIN	MAX	FREE AREA	LOAD RATING		NO HUB (STANDARD)	PUSH ON (P)	THREADED (T)	INSIDE CAULK (X)	PVC/ABS (-30)/(-31)
12" (305)	2 1/4" (57)	4 1/8" (105)	33 in ² (21,920 ²)	S.S. (-3) / D.I. (-4)	2" (51)	6" (152)	6 1/8" (156)	5 7/16" (138)	6 1/4" (159)	7 1/8" (181)
				ANSI/ASME LOAD CLASS	3" (76)	6" (152)	6 1/8" (156)	5 7/16" (138)	6 1/4" (159)	7 3/8" (187)
				"SPECIAL DUTY" (OVER 10,000 LBS.)	4" (102)	6" (152)	6 1/8" (156)	5 7/16" (138)	6 1/4" (159)	7 3/8" (187)
					5" (127)	6" (152)	—	5 7/16" (138)	6 1/4" (159)	—
					6" (152)	7 1/4" (184)	7" (178)	7" (178)	6 1/4" (159)	—

- SUFFIX OPTIONAL VARIATIONS**
- 3 Stainless steel strainer (vener) and cover
 - 4 Ductile iron strainer
 - 5 Sediment bucket
 - 6 Security screws (T-20 Torx & pin)
 - 7 1/2" trap seal primer connection
 - 8 Backwater valve (2", 3", 4")
 - 11 Acid resistant epoxy coated body
 - 13 Galvanized body
 - 15 Extension
 - 21 Secondary flat stainless steel strainer (2", 3", 4")
 - 28 Stainless steel body (Type 304)
 - 30 PVC socket connection body
 - 31 ABS socket connection body
 - 34 Closure plug
 - 40 Underdeck clamp

- SUFFIX OPTIONAL VARIATIONS**
- 41 Sump receiver
 - 90 Threaded side outlet (2", 3", 4")
 - 90NH No hub side outlet (2", 3", 4")
 - 95 Client logo
 - BA Buy American Act compliant product
 - C Membrane Clamps
 - C1 Clamp rings for low rough-in (min. 1/2" (13))
 - HP Heel proof grate (1/4" maximum grate opening size, -3 only)
 - J 6" x 3" x 1" funnel
 - (Standard) No hub outlet
 - MG MI-GARD Floor Drain Trap Sealer (2", 3" or 4")
 - P Push on outlet
 - PA Pennsylvania Steel Act compliant product
 - T Threaded outlet (2", 3", 4")
 - X Inside caulk outlet
 - Z Extended wide elastomeric flange

Job Name: _____ Page No: _____

Section No: _____ Contractor: _____

Schedule No: _____ Purchase Order No: _____