

Location: _____



F1130C

FLOOR DRAIN WITH INTEGRAL DEEP SEAL TRAP AND CLEANOUT

Specification: MIFAB® Series F1130C lacquered cast iron floor drain with anchor flange, cast iron membrane clamp ring with primary and secondary weepholes for waterproofing membrane, seepage collection sump, integral deep seal trap, and standard reinforced (specify diameter), (specify material finish) strainer, and standard reinforced 5" (127) diameter (specify material finish) top assembly floor cleanout with access cover, "O" ring Test Seal and plug with primary gasket seal.

Function: Used in kitchens, supermarkets and other membrane finished areas where side outlet body connection with integral deep seal trap and cleanout access is required. Round adjustable strainer and round floor cleanout top is used for all types of poured finished floors.

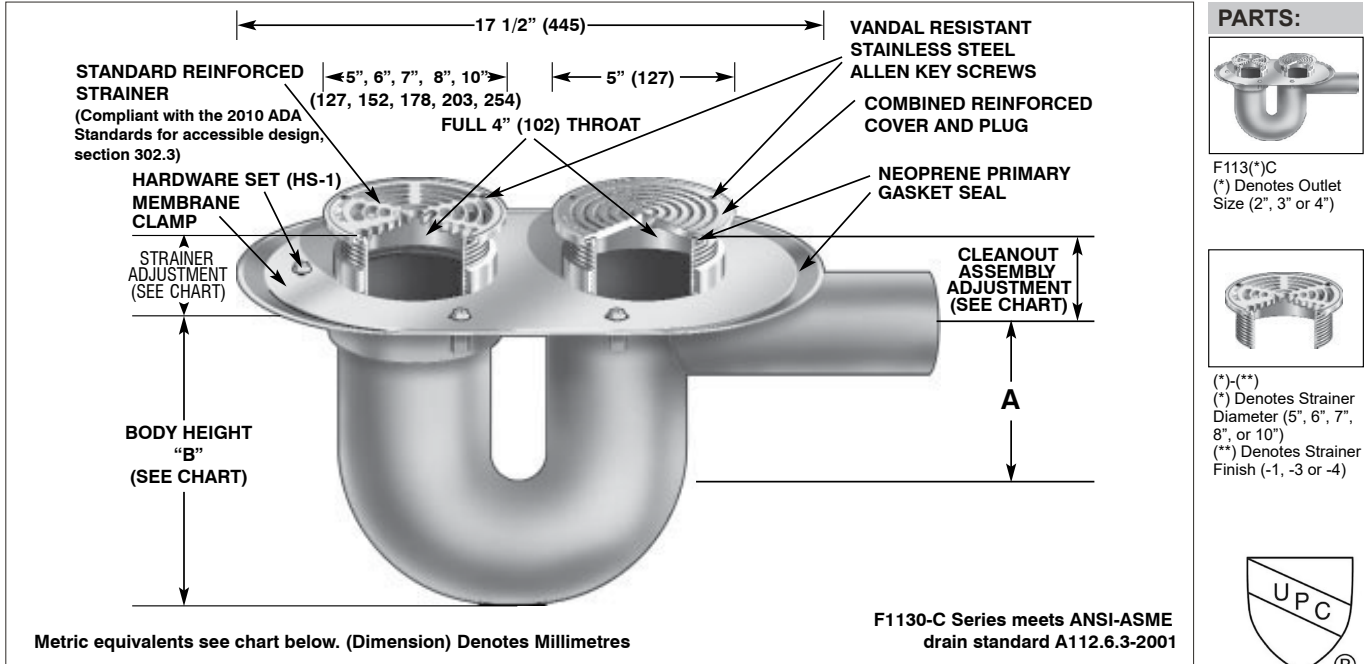

Metric equivalents see chart below. (Dimension) Denotes Millimetres

F1130-C Series meets ANSI-ASME drain standard A112.6.3-2001

STRAINER SIZE	STRAINER ADJUSTMENT		ANSI/ASME RATING				CLEANOUT ASSEMBLY SIZE	CLEANOUT ASSEMBLY ADJUSTMENT		LOAD RATING		PIPE SIZE	BODY HEIGHT		
	MIN	MAX	FREE AREA	LOAD RATING				MIN	MAX	N.B. (-1) LBS.	S.S. (-3) LBS.		A	B	
				N.B. (-1) Lbs.	S.S. (-3) Lbs.	D.I. (-4) Lbs.									
5" (127)	1 5/8" (41)	2 5/8" (67)	8 in² (5200²)	Up To 2000	5000 to 7499	UP TO 7499	5" (127)	1 5/8" (41)	2 5/8" (67)	UP TO 4,999	5000-7499	2" (51)	5 3/8" (137)	13 1/2" (343)	
6" (152)	1 5/8" (41)	2 5/8" (67)	9 in² (5800²)	Up To 2000	5000 to 7499	-				D.I. (-4)		3" (76)	6" (152)	13 1/2" (343)	
7" (178)	1 5/8" (41)	2 5/8" (67)	12 in² (7700²)	UP TO 2,000	5000-7499	-				UP TO 7,499		4" (102)	6 1/4" (159)	13 1/2" (343)	
8" (203)	1 7/8" (48)	2 5/8" (67)	18 in² (11600²)	Up To 2000	5000 to 7499	UP TO 10000									
10" (254)	1 1/16" (17)	2 1/4" (57)	26 in² (17170²)	-	5000 to 7499	-									

SUFFIX	OPTIONAL VARIATIONS
-1	Nickel bronze strainer
-3	Stainless steel strainer
-4	Ductile iron grate (5" x 8" only)
-5	Sediment bucket
-6	Security screws (T-20 Torx & pin)
-7	1/2" trap seal primer connection
-8	Backwater valve (2", 3", 4")
-11	Acid resistant epoxy coated body
-13	Galvanized body
-15	Extension
-16	Square top
-34	Closure plug

-49	Chrome Plated Strainer
-50	Lacquered cast iron funnel
-95	Client logo
-BA	Minimum 51% material cost made in the USA
-F4	4" Round funnel
-F6	6" Round funnel
-G	Oval 4" x 9" funnel
-HP	Heel proof grate (1/4" maximum grate opening size, -3 only)
-J	6" x 3" x 1" funnel
-MG	MI-GARD Floor Drain Trap Sealer (2", 3" or 4")
-PA	Pennsylvania Steel Act compliant product
-Z	Extended wide elastomeric flange

CALIFORNIA PROPOSITION 65 WARNING. This product contains chemicals known to the State of California to cause cancer and birth defects or other reproductive harm.

Job Name: _____ Page No: _____
 Section No: _____ Contractor: _____
 Schedule No: _____ Purchase Order No: _____