

Location: \_\_\_\_\_



**CESW**

**WIDEBODY, WATER AND STEAM  
SUPPORT, MEDIUM LOAD SERIES**

**Specification:**

**Dimensions** - 24" Crossbeam Width x 12" Base Length x 24" to 48" Height (See Chart)

**Material**

Base - 100% recycled rubber, UV resistant  
Crossbeam and Uprights - 1 5/8" x 1 5/8", 12 gauge galvanized steel slotted strut  
**Maximum Load** - 600 lbs.



**Environmentally Friendly  
made from  
100% recycled tires**

**Function:** The CESW Series can support gas and refrigeration piping systems, cable tray, electrical conduit, multiple lines, HVAC equipment and many other applications. It is designed for rooftop applications requiring a heavier load bearing, and is suitable for most types of roofing material or other flat surfaces. The wide bases provide this series with added stability. The CESW Series is suitable for use with one or two pipe hangers (by others).

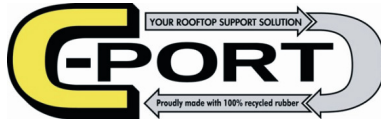

Consult with roofing consultant for allowable loads.

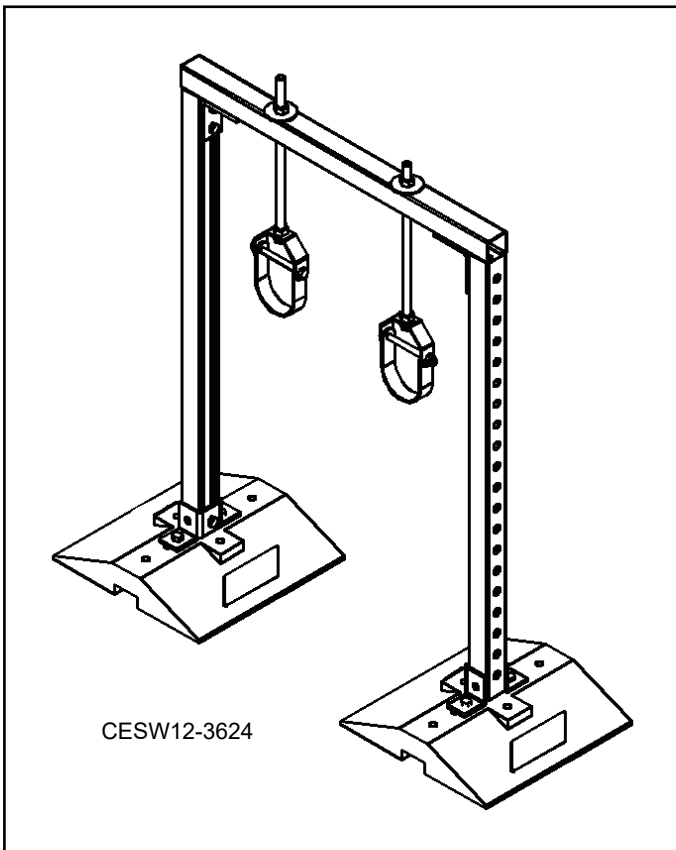

CESW12-2424 illustrated. Pipe hangers by others.

MODEL NO.	HEIGHT (H)	CROSSBEAM WIDTH	BASE WIDTH	BASE LENGTH	WEIGHT
CESW12-2424	24" (610)	24" (610)	12" (305)	12" (305)	27.80 lbs.
CESW12-3624	36" (914)	24" (610)	12" (305)	12" (305)	31.12 lbs.
CESW12-4824	48" (1219)	24" (610)	12" (305)	12" (305)	34.44 lbs.

Channel also available in corrosion resistant stainless steel or aluminum.

CALIFORNIA PROPOSITION 65 WARNING. This product contains chemicals known to the State of California to cause cancer and birth defects or other reproductive harm.

Job Name: \_\_\_\_\_  
Section No: \_\_\_\_\_  
Schedule No: \_\_\_\_\_

Page No: \_\_\_\_\_  
Contractor: \_\_\_\_\_  
Purchase Order No: \_\_\_\_\_